



SNHD and Senate Bill 92

Sidewalk Vendors



Direct Impacts on SNHD

- Must accept identification cards from non-US issued authorities for food handler safety cards (no change needed)
- Must adopt payment plans for sidewalk vendor permit application fees
- Must adopt regulations for sidewalk vending by the end of 2025
 - 2023 Food Regulations allows for permitting sidewalk vendors as open-air vendors
 - SNHD would not need to draft new regulations now
- Must adopt regulations the Task Force deems “necessary”

Path to SNHD Permit

- SNHD 2023 regulations (Ch 11) allow for permitting as Open-Air Vendor
 - Will issue a waiver for regulation (11-201(A)) which requires operating from fixed location
 - Equipment requirements will be dependent upon menu and extent of food handling



Open Air Vendor Equipment Requirements (11-102.1)

- Be limited to 200 square feet
- Provide an adequate number of handwashing sinks for open-food handling that meet the following criteria:
 - A handwashing sink must be stocked with liquid hand soap in a pump dispenser, single-use paper towels, and a garbage can
 - The handwashing sink must be located within 10 feet of the open-food handling area and ready for use prior to any open food handling,
 - **(a)** Provide a continuous flow of hot and cold running water without the use of a manual pump,
 - **(b)** Be self-contained, and
 - **(c)** Be equipped with an integral five-gallon minimum potable water supply tank and a wastewater storage tank that is at least 15% greater than the potable water supply

Open Air Vendor Equipment Requirements

- Provide overhead protection for food preparation areas unless prohibited by fire code
- Operate on a surface such as asphalt or concrete and provide adequate groundcover contamination from excessive food debris and grease buildup on the ground
- Food equipment must meet the standard for sanitation set by an American National certification program
 - Common acceptable certifications: NSF, ETL Sanitation Listed; UL Sanitation



Example Unit

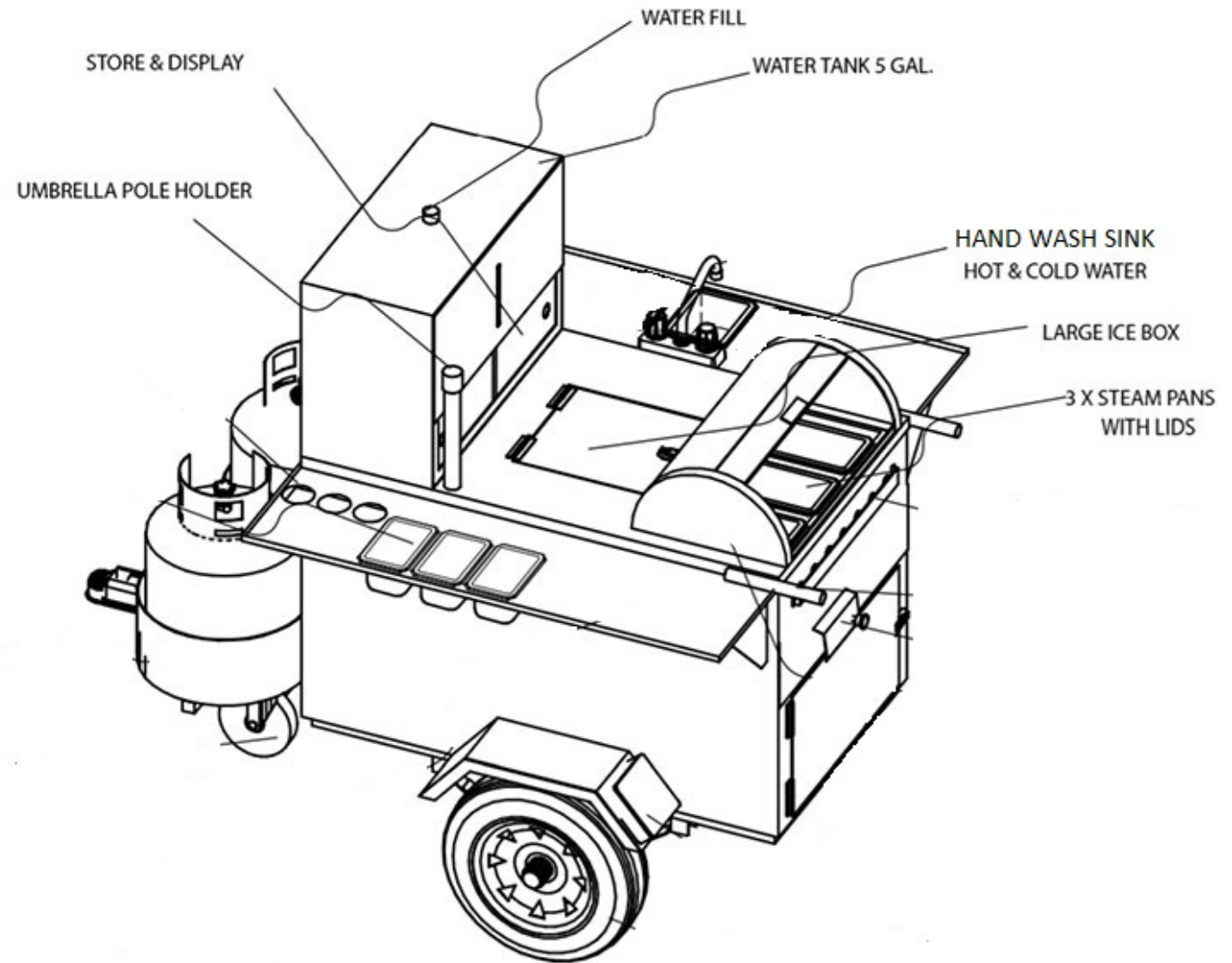

Steps to Apply for Permit

- Submit application to SNHD:
 - Equipment plans and specifications
 - Menu
 - Commissary agreement
 - Ownership information
 - An inspector will contact the owner to schedule a permitting inspection of the unit once all paperwork and payments have been processed

Operational Requirements for Sidewalk Vendors

- Sidewalk Vendors must follow all current regulations, which mandates they have a permit from the Health Authority.
- Food offered to the public may not be prepared from home kitchens.
- Food must be:
 - Ingredients bought the same day and prepared at the sidewalk vendor location, or
 - Ingredients stored and food prepared at a permitted commissary location.
- May not conduct complex food processes such as cooling
- May not hold open TCS food for next-day service



SIDEWALK VENDOR FEES FOR OPEN AIR VENDOR PERMIT (AS OF 5/14/24)

Plan Review Fee

• \$368

Annual Permit Fee

• \$376

Each Unit Fee

• \$119.38

Total fee

• \$863.38*

*This fee is for one unit.

Once approved only the permit fee will be billed yearly; the plan review and unit fee are only charged initially for approval of the unit